

Premium Booth 5mW x 3mD One side open

SD-E-W15
5mW x 3mD x 3.5mH

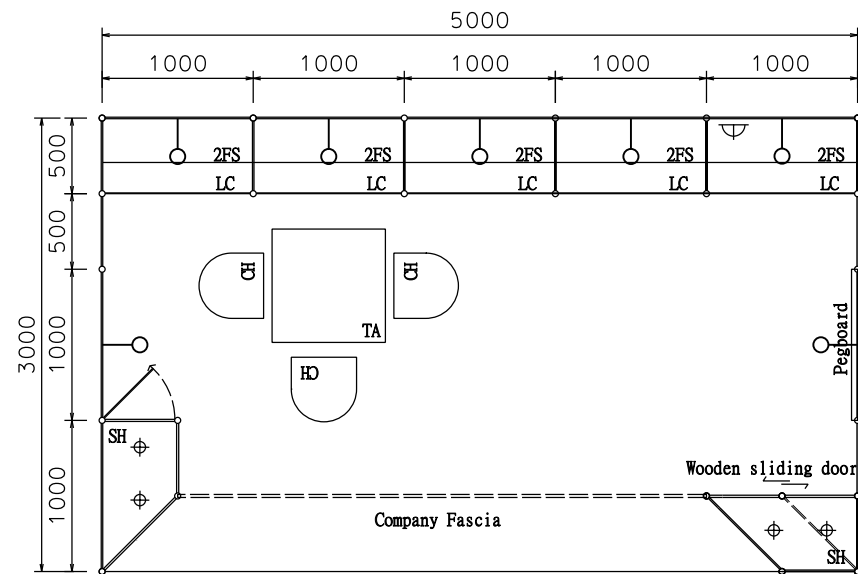

PLAN

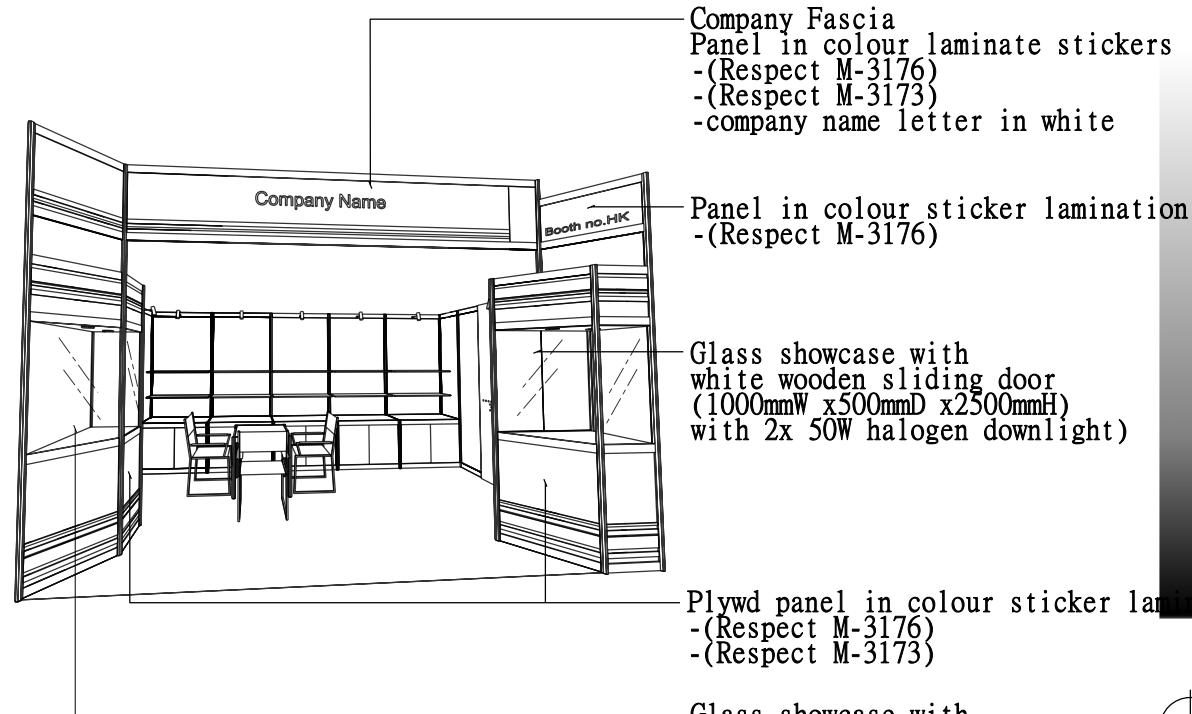

PERSPECTIVE N.T.S

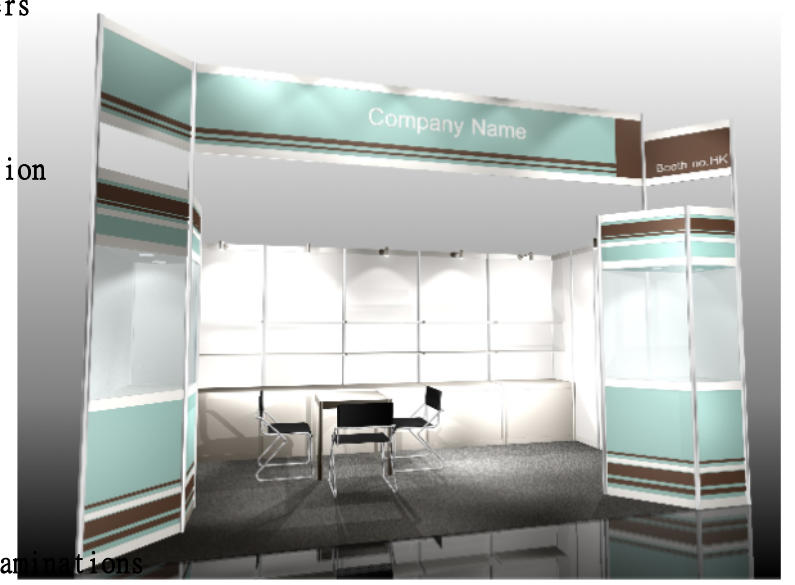

COLOUR PERSPECTIVE N.T.S

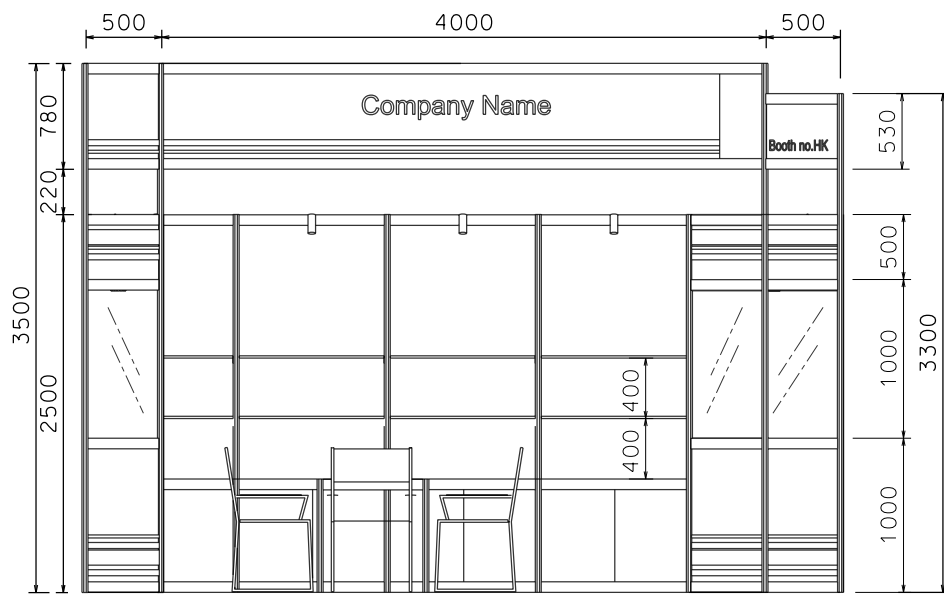

FRONT ELEVATION

BOOTH SPECIFICATION		QTY
	Front glass showcase in sticker lamination with white wooden swing door. 2 x (50W) halogen downlight (1m W x 0.5mD x 2.5m H)	
	Front glass showcase in sticker lamination with white wooden sliding doors. 2 x (50W) halogen downlight (1m W x 0.5mD x 2.5m H)	
	Lockable cabinet (1mL x 0.5mD x 0.75mH)	5
	Wooden shelf (flat) (1mL x 0.3mD)	10
	Pegboard with 30 hooks (1mW x 2.5mH)	1
	Square meeting table (0.7m X 0.7m x 0.75mH)	1
	Black leather chair	3
	Longarmed spotlight w/23 watt energy saving lamp (yellow)	7
	500w Square pin power socket	1

FILE PATH - L:\Local Fair Premium Booth 2011\SD-Layouts\SD-E layout\SD-C-2dLayout.dgn

	NOTES UNLESS OTHERWISE SPECIFIED ALL DIMENSIONS ARE IN MM.	REVISION 16-07-2009 20-01-2010	DATE: 20-01-2010	TITLE Premium Booth SD-E-W15	PROJECT PREMIUM BOOTH 5m x 3m DATE: XXXXXXXX	SHEET SD-E04
	SCALE: 1 : 50 (A3)			
.....		CHECKED BY:			